



Compensation Plan

August 2008

INTRODUCTION

This presentation is designed to give you a comprehensive understanding of the ONE Group Compensation Plan.

To start the Slide Presentation, click the Slide Show symbol which can be found near the bottom left corner of your computer screen.

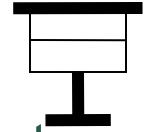

If you are new to the Company, you can go through the Plan in an easy-to-follow sequence by clicking the “DOWN” arrow on your computer keyboard. In the same manner, you can go back through the slides by clicking the “UP” arrow.

If you are generally familiar with the Compensation Plan you can navigate directly from the INDEX page.

Clicking on the RED “index” button at the top right of any page will take you directly to the INDEX page.

INDEX

Levels of Membership

Preferred Customer

Retail Outlet

Representative

Definitions

Autoship or Business Protection

Sponsor Tree

Retirement Tree

Customer & Retail Bonuses

Sponsor Bonuses

Retirement Bonuses

Builders Bonus

Loyalty Bonus

Executive Pools

Bonus Payout

Promotion

Ranks

Getting Started

Off to a Fast Start

Summary

LEVELS of MEMBERSHIP

There are 3 levels of membership in the
ONE Group Compensation Plan

- Preferred Customers

Individuals who want to buy product occasionally for personal use.

- Retail

Retail outlets, including, e-tailers and professional home delivery businesses that do not want to build a Multi-Channel Enterprise.

- Representatives

Entities who want to build a Multi-Channel Enterprise, including Fundraising Organisations.

INDEX

PREFERRED CUSTOMER

- Is buying ONE Group products as a;
Guest of a Home Shopping Presentation.
Supporter of a fundraising effort.
Client/Patient of a Health or Beauty Professional Representative.
Casual shopper.
- Pays no Joining Fee.
- Buys products directly from ONE Group.
- May upgrade to Representative at any time.
- Sponsor receives up to 30% of the retail price of each order.
- Sponsor Bonuses are paid upline through the Sponsor Tree.

Continue

PREFERRED CUSTOMER

Ordering

INDEX

Prices are retail (ex tax) before applicable discount.

Prices are local currency for Australia, NZ, UK, USA, Canada & Japan

All other destinations are USD.

Initial order - Under \$100 (£50) - No Discount + Shipping

Over \$100 (£50) - No Discount (Free Shipping)

Subsequent Orders under \$100 (£50) - 10% Discount + Shipping

Subsequent Orders over \$100 (£50) - 10% Discount (Free Shipping)

Loyalty Program - Once total purchases, incl. the initial order, exceed 150 Points, the next order attracts a 20% discount, after which, the discount reverts to 10% until 150 Points is attained again. Points do not accumulate on the 20% discount order.

Orders under \$100 (£50) attract a \$7.95 (£3.95) Shipping Charge.

RETAIL

- Businesses that have a physical premises that retail to the public and are health/beauty related (health food stores, hairdressing salons, professional home-delivery businesses and professional e-commerce websites etc.)
- The BV of 'retirement' orders by retail outlets, is included in the worldwide Loyalty Bonus & Executive Pools.
- Only Managers and above may sponsor a retail outlet, but only after they have completed the Retail Training and the allocation process.
- Only available in countries that have been opened to retail.
- Currently the countries opened for Retail are; Australia, New Zealand, United States and Canada.

Continue

RETAIL

Ordering

Prices are retail (ex tax) before applicable discount.

Prices are local currency for Australia, NZ, USA, UK & Canada.

Orders - Retail Price less 40%
66.67% Mark-up

Orders under \$100 attract a \$7.95 (£3.95) Shipping Charge.

All other orders by retail outlets are freight free - Conditions apply

INDEX

REPRESENTATIVE (incl. Health & Beauty)

●Wants to build a Multi-Channel Enterprise.

•Pays a Joining Fee of;

•AU\$80.00 (+GST) , US\$60.00, NZ\$90, CN\$68 or GB£34

Incl.

AU\$35.00 Administration Fee.

AU\$30.00 Set-up & hosting of personalised sub-domain website

AU\$10.00 for Basic Training.

AU\$ 5.00 to the David Suzuki Foundation.

•Annual Renewal Fee - AU\$40.00 (+ GST), US\$30, NZ\$45, CN\$34 or
GB£17

•Buys product directly from ONE Group.

Continue

REPRESENTATIVE (incl. Health & Beauty)

Ordering

Continue

Prices are retail (ex tax) before applicable discount.

Prices are local currency for Australia, NZ, UK, USA & Canada.

All other destinations are USD.

Under \$100 (£50)	- Retail Price less 10% + Shipping
\$100 - \$249 (£50 - £124)	- Retail Price less 10% (Free S/H)
\$250 - \$599 (£125 - £299)	- Retail Price less 20% (Free S/H)
\$600 - \$899 (£300 - £449)	- Retail Price less 30% (Free S/H)
\$900 + (£450 +)	- Retail Price less 40% (Free S/H)

Orders under \$100 (£50) attract a \$7.95 (£3.95) Shipping Charge.

*50 – 99 PV, A/S or BP - Retail Price less 20% (Free S/H)

*100 PV or more, A/S or BP - Retail Price less 30% (Free S/H)

*Applies to orders placed 30 days after joining if the Representative is on AS or BP

OFF TO A FAST START

A Representative whose orders total **250 PV +** within 30 days of joining, will be immediately promoted to Senior Associate. **Single orders over 250 PV** within 30 days of joining, **attract a 30% discount.**

If, within their first 30 days, a Senior Associate personally sponsors, at least 3 Representatives who also attain the rank of Senior Associate, they will be promoted to Manager for the following 6 months. After the 6-month period has lapsed, if the “Grandfathered” Manager has not attained the rank of Manager in their own right, they will revert to Senior Associate.

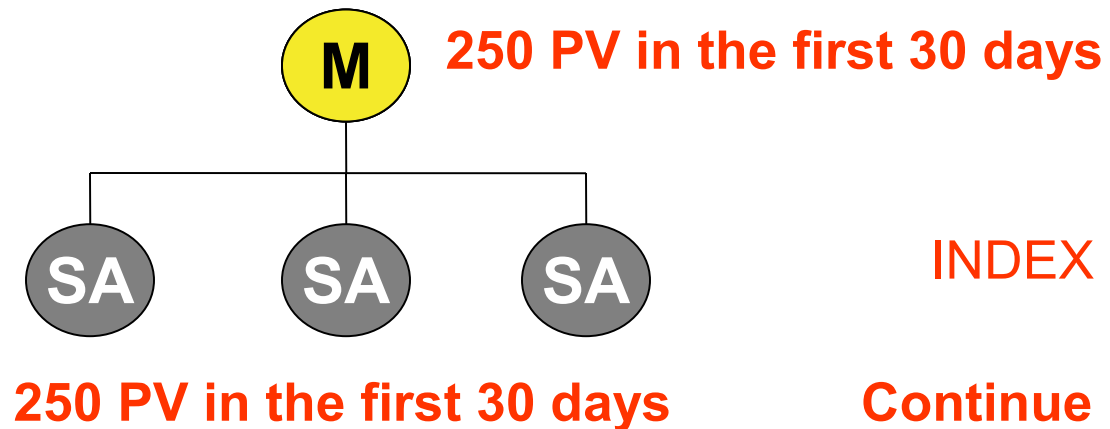

REPRESENTATIVE (incl. Health & Beauty)

Home Shopping Presentations - MiSpa

- Representative does the presentation at the home of the Host.
- Guests order product on supplied order forms and pay by credit card, cash or cheque.
- Representative receives a Customer Bonus of 30% of the retail price of orders.
- Sponsor Bonuses are paid upline through the Sponsor Tree.

Continue

REPRESENTATIVE (incl. Health & Beauty)

Host Gifts – Free with \$700 in party sales plus 2 bookings
Choose from one of the following:

- Skin Essentials Pack
- Luxuriously Rejuvenating Indulgence Pack
- Ambrosia Essence
- Bathroom Changeover Pack

Continue

REPRESENTATIVE (incl. Health & Beauty)

Fundraising – Please note that the fundraising program is currently under review through pilot testing. The notes below are for reference only.

- The Organisation, once allocated, is sponsored as a Representative. That organisation can be a school, sporting club, church group, service club or the like.
- There is no cost to the organisation to join and no monthly maintenance is required for the organisation to receive bonuses.
- Supporters of the organisation order products from ONE Group on the organisation's website [www."organisation".mifundraiser.com](http://www.)
- Products are delivered directly to the entity making the order.
- The Organisation receives 30% of the retail price of each initial order and up to 20% of subsequent orders.
- Sponsor Bonuses are paid upline through the Sponsor Tree.

Continue

REPRESENTATIVE (incl. Health & Beauty)

Clients/Patients

- The Clients/Patients of a Health or Beauty Profession Representative, may order products directly from ONE Group through the Professional's website.
www.'username'.mionegroup.com
- The Representative receives 30% of the retail price of the initial order by a Client/Patient and up to 20% on subsequent orders.
-  Sponsor Bonuses are paid upline through the Sponsor Tree.

INDEX

GIVING BACK



David
Suzuki
Foundation

www.davidsuzuki.org



Nature is our home. And just as we take care of our house, we also must take care of nature.

Unfortunately, with six billion of us now living under one roof, we are gradually eroding the services nature provides – even though we depend on them for our quality of life and our future.

Since 1990, the David Suzuki Foundation has worked to find ways for society to live in balance with the natural world that sustains us. Focusing on four program areas – oceans and sustainable fishing, forests and wild lands, climate change and clean energy, and the web of life - the Foundation uses science and education to promote solutions that help conserve nature.

INDEX

DEFINITIONS

Points. Each product has a point value assigned to it.

Personal Volume or PV is the total of the points of all the products purchased by a Member during a calendar month. PV is reset to ZERO at the beginning of each calendar month.

Group Volume or GV is the total of a Member's PV and the PV of all the Members in their Downline organisation. GV is reset to ZERO at the beginning of each calendar month.

Active Representative. To be eligible to receive bonuses, Representatives must have a PV of at least 50 Points (approx. \$80 (£45) depending on the products ordered) during a calendar month.

Bonus Value or BV is the value in US Dollars assigned to each product for bonuses. If a Representative is entitled to 25% of an order whose BV is 60, the Representative would be entitled to a bonus of US\$15.00.

Continue

BONUS VALUE

A traditional manufacturer establishes a competitive wholesale price to allow for a 66.7% mark-up. In other words, the retail price less 40.0% equals the wholesale price. If you take away the cost of goods, expenses and a profit margin, you are left with an amount for marketing.

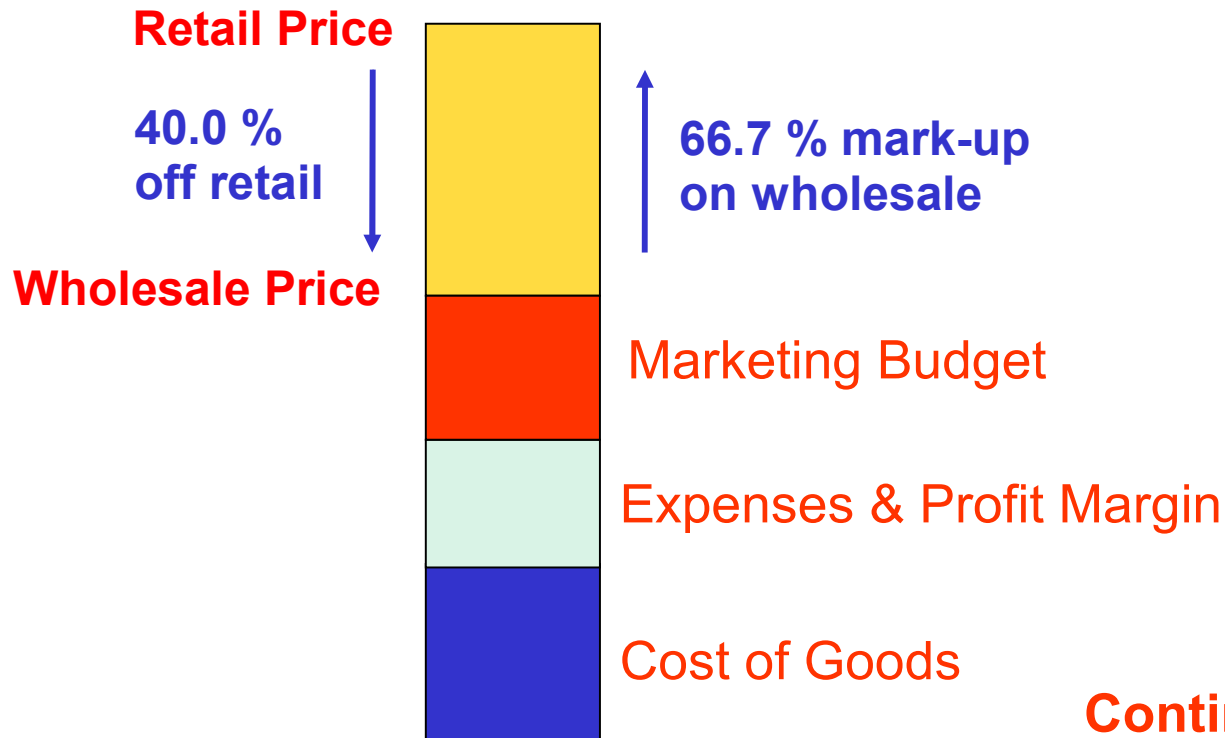

Continue

BONUS VALUE

A ONE Group Multi-Channel Enterprise does the same, however the marketing budget is paid to the Representatives as Bonuses.

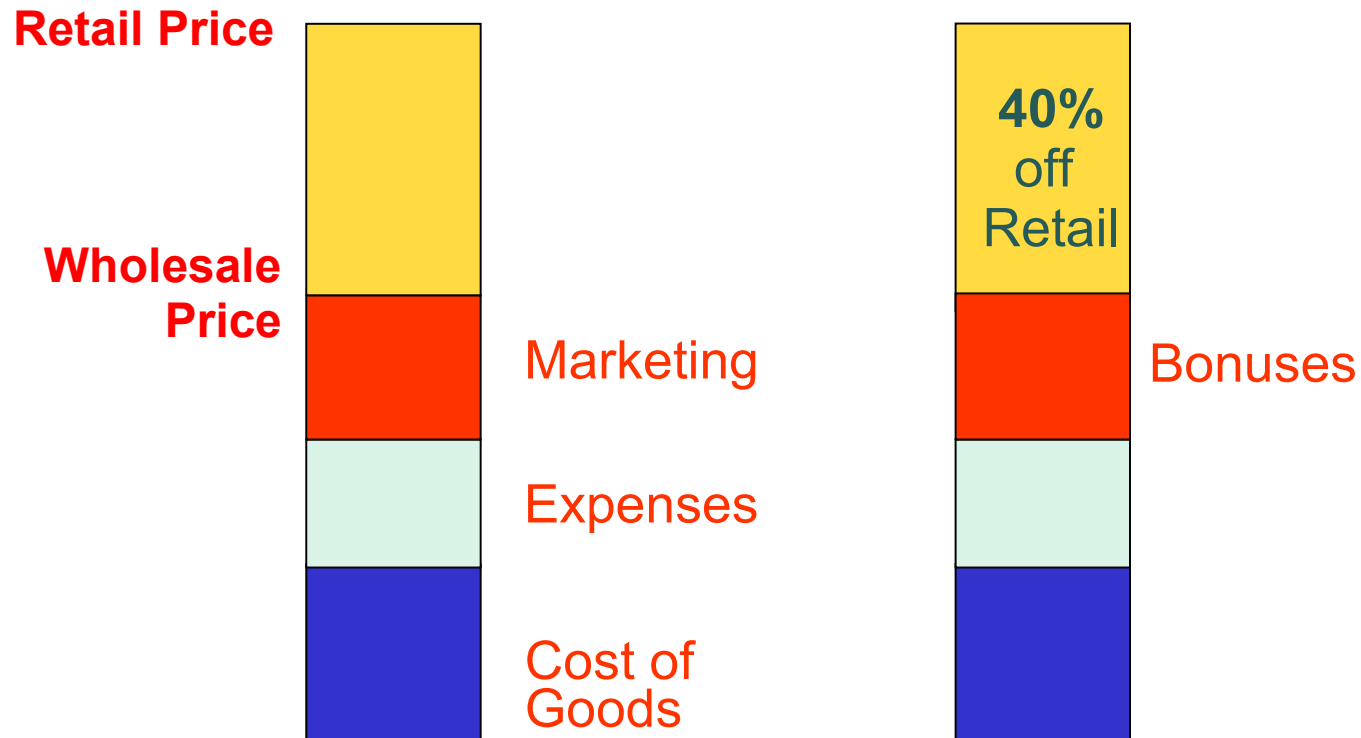

Traditional Business

ONE Group

Continue

BONUS VALUE

Discount %

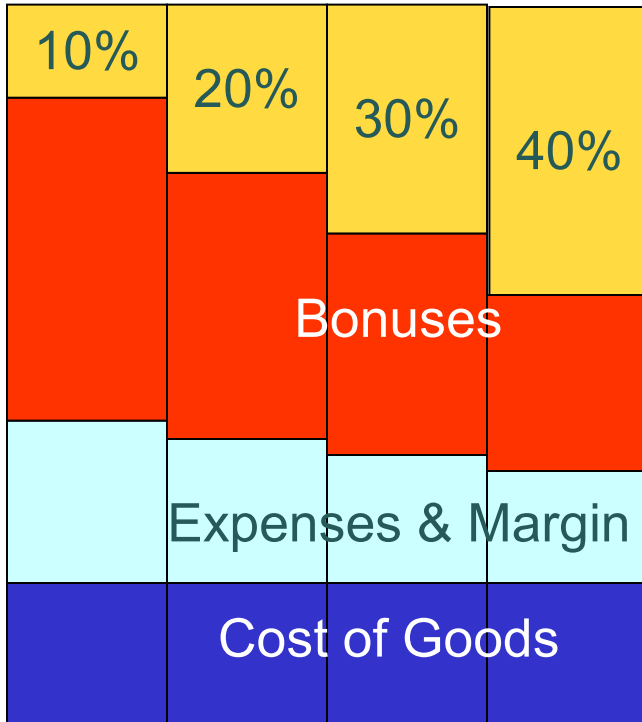

The Bonus Value (BV) on a product, decreases as the Discount % increases

BONUS VALUE (BV)

$$\begin{array}{r}
 \text{Money received by ONE Group} \\
 \text{less Cost of Goods} \\
 \text{less Expenses \& Margin \& Shipping} \\
 = \text{Amount for Bonuses i.e. BV}
 \end{array}$$

BV is in US Dollars
 9.63 BV = US\$9.63

Continue

AUTOSHIP or BUSINESS PROTECTION

Autoship or Business Protection is an easy way to ensure that a Membership is active and eligible to receive all bonuses. ONE Group has made a point of keeping the cost of products at a competitive level while ensuring monthly requirements are not excessive. Consequently, the monthly commitment is just 50 Points, which equates to around \$80.00 AUD (£40) depending on the products ordered.

The standard Autoship or Business Protection order is 2 x In-Liven. However, the content of an Autoship or Business Protection order may be changed by the Representative in the Member's Area of the website up until 3 days before the Autoship or Business Protection order is due to be run on the computer.

Continue

AUTOSHIP or BUSINESS PROTECTION

Autoship and Business Protection are only available to Representatives.

Autoship. By signing for Autoship, the Member is committing to a regular monthly order, which starts the month after they join. The monthly order will be sent out on the 5th, 10th, 15th or the 20th of each calendar month, depending on the date of their joining.

A Representative receives 20% off the retail price of orders from 50PV – 99PV and 30% off the retail price of 100 PV + orders as long as those orders are placed at least 30 days after joining.

Autoship orders are sent out regardless of the ordering activity by the Representative during the month.

Continue

AUTOSHIP or BUSINESS PROTECTION

Autoship and Business Protection are only available to Representatives.

Business Protection. A Representative who has signed up for Business Protection, receives 20% off the retail price of orders from 50PV – 99PV and 30% off the retail price of orders of 100 PV + as long as those orders are placed at least 30 days after joining.

By signing for Business Protection, a Representative is committing to receive a standing order of at least 50 PV on the 25th of every month unless 50PV of orders are placed prior to the 22nd of the month.

INDEX

SPONSOR TREE

When a Representative sponsors (introduces) a new Customer, Retailer or Representative to the Company, that new Member will always be placed front-line on the Sponsor Tree.

Customers are **ONLY** placed front-line on the Sponsor Tree so their orders always count for Sponsor Bonuses.

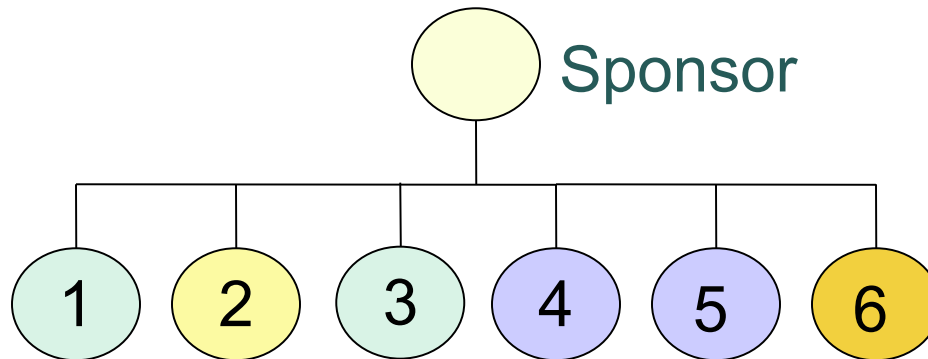

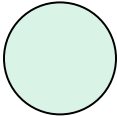
 Existing personally sponsored Rep

 New Representative

 Existing Retailer

 New Customer

INDEX

RETIREMENT TREE

As well as being front-line on the Sponsor Tree, a new Representative or Retailer will also be placed front-line on the sponsoring Representative's Retirement Tree.

A Representative only has to build 3 Teams in the Retirement Tree to reach the top rank in the Compensation Plan.

Once a new Representative or Retailer has been placed front-line on the Retirement Tree, the sponsoring Representative will receive an e-mail from the Company giving them 30 days to move the new Representative or Retailer to an existing Team. If the new Representative or Retailer is not moved within the 30-day period, they will remain front-line to the sponsoring Representative in the Retirement Tree.

Continue

RETIREMENT TREE

Before Move

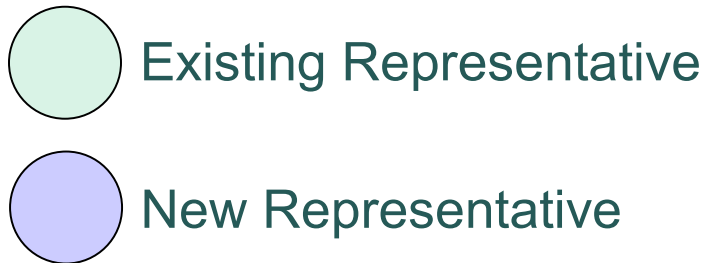
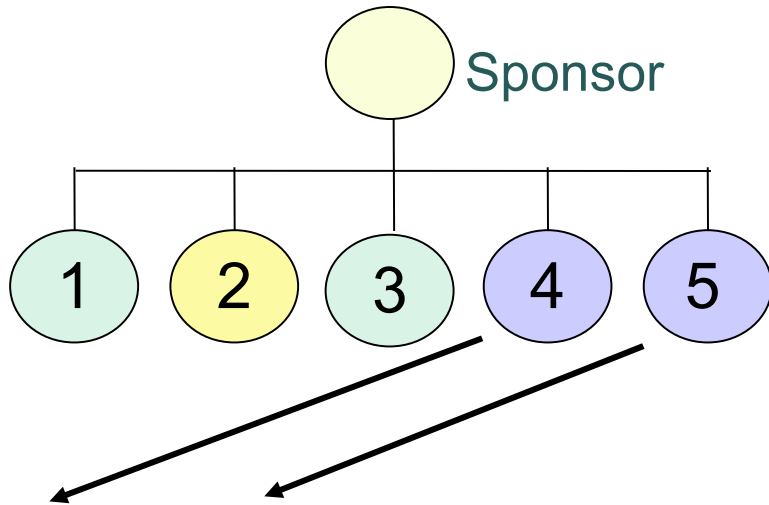

After Move

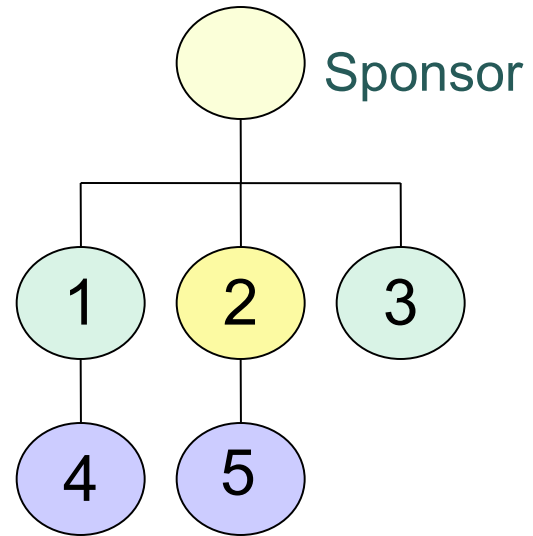

Continue

RETIREMENT TREE

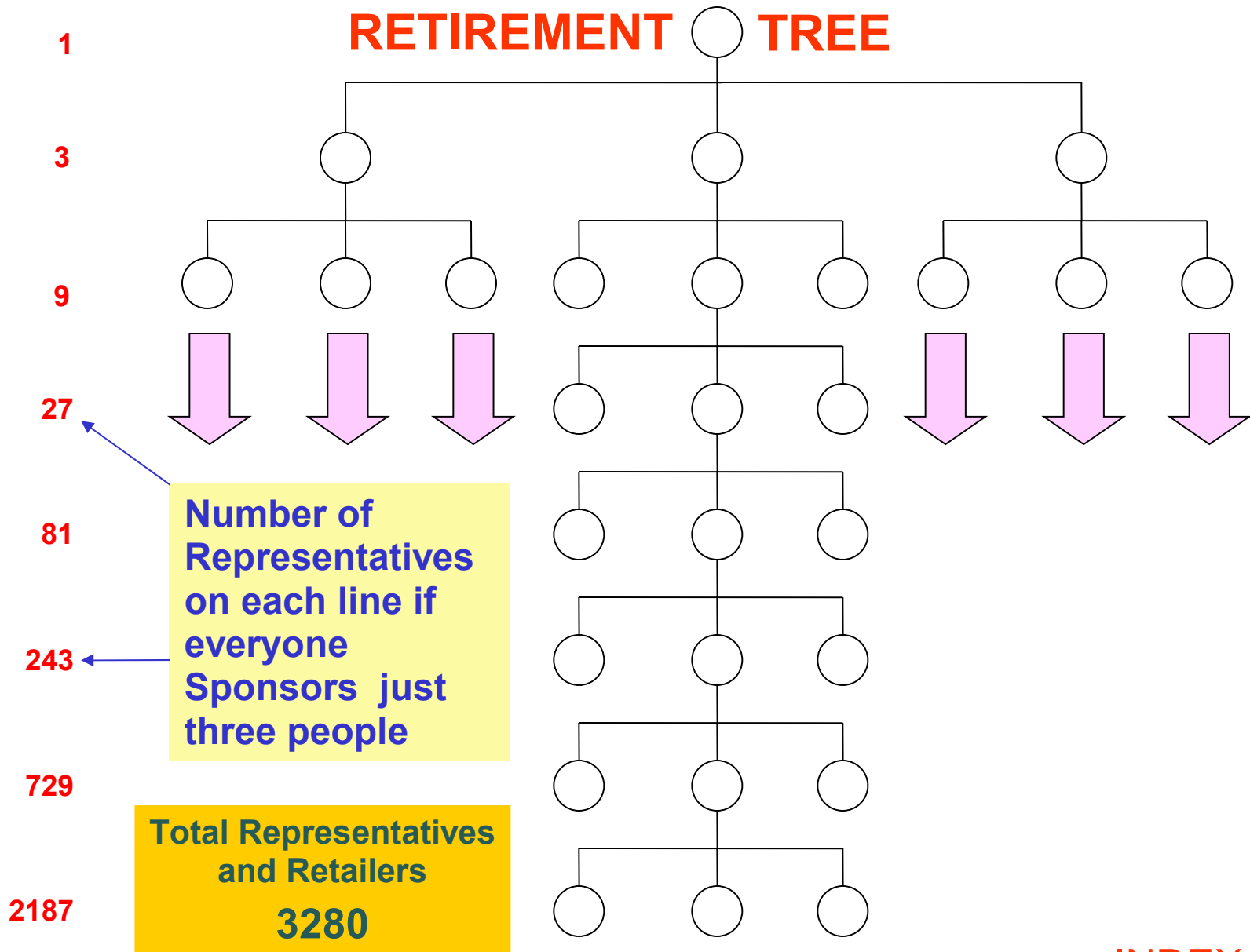

INDEX

CUSTOMER BONUS

A Customer Bonus of 30% of the retail value of initial orders (up to 20% on subsequent orders) by Preferred Customers will be paid to the Sponsoring Representative. Sponsor Bonuses will be paid upline from there, based on the BV of a 30% discount order.

The Customer Bonus is paid daily.

Continue

CUSTOMER BONUS

This is an example of the Customer Bonus for a \$150 (£75) order by a new Preferred Customer

● The Sponsor earns 30% of the order - \$45 (£22.50)

\$150 (£75) order

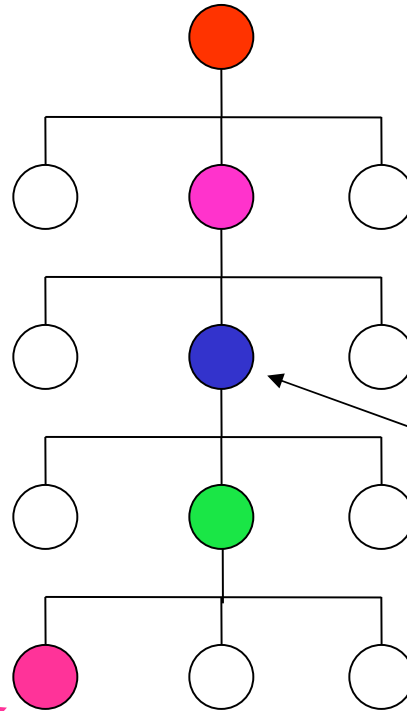

Sponsor Bonuses are paid upline from here

Continue

RETAIL BONUS

A Retail Bonus of US\$50 will be paid to an active Representative who has sponsored a retail outlet if the Retail Outlet places a fast start order of a minimum of 250PV within the first month. The Representative will receive a 5% bonus on subsequent orders from the retail outlet they have sponsored. Normal Retirement Bonuses will be paid based on the BV of a 50% discount order. If the Sponsoring Representative is not active, no Retail Bonus will be paid and the Retirement Bonuses will be based on a 40% discount order.

e.g. A shop that joined 3 months ago, places an order for \$2,400 (£1,200) (retail value). The shop pays \$2,400 (£1,200) less 40% = \$1440 (£720). The Representative who has the allocation receives a Retail Bonus of \$120 (£60) (5% of the retail value).

Retail Bonuses are generated with the Retirement Bonuses and becomes 'cleared funds' as soon as the order has been paid for.

There is no Retail Bonus paid on orders over \$7,500 (£3,750).

Continue

RETAIL BONUS

Sponsor Tree

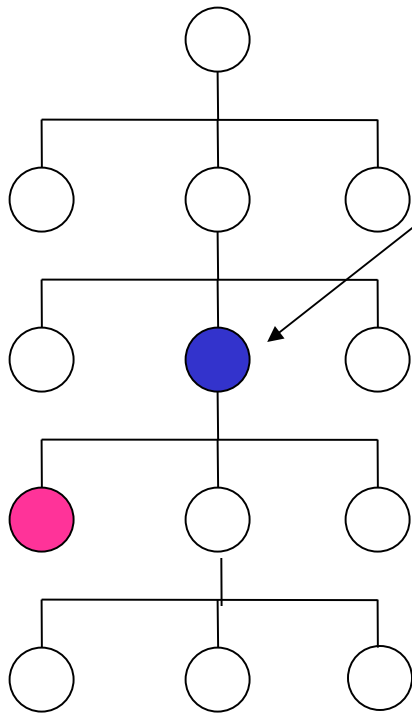

Active Sponsor receives 5% or \$120 (£60) of ongoing orders

Retirement Bonuses are paid upline, based on a 50% discount order



Retail Outlet

\$2,400 (£1,200) order

Retirement Tree

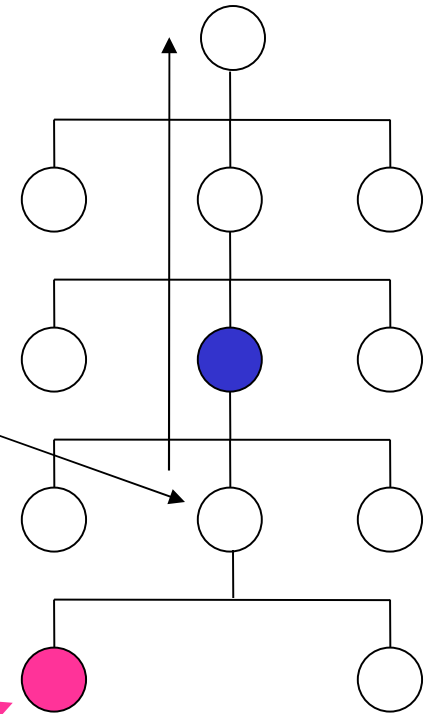

INDEX

SPONSOR BONUSES

Sponsor Bonuses are paid upline to active Representatives on the BV of orders by Preferred Customers, regardless of their time with ONE Group, as well as new Affiliates and Representatives in their first 30 days with the Company. In fact, depending on their rank, a Representative can be paid from 25%-5% of the BV of orders up to seven (compressed) levels deep.

Sponsor Bonuses are calculated daily.

After the 15-day refund period has lapsed, proceeds are paid immediately into the Representative's Bonus Account where they will have immediate access to the funds.



5%	ME	Man. Exec. or higher
	M	
5%	E	2nd Exec. or higher
10%	E	Executive or higher
	M	
10%	M	Manager or higher
15%	M	Snr Assoc. or higher
15%	A	Associate or higher
25%	A	Sponsor (Any Rank)
		New Member
		Continue

SPONSOR BONUSES

The first ME or SE above this SE would also receive 5%

This is an example of the Sponsor Bonus payout (%) for this 100 BV order

100 BV Order

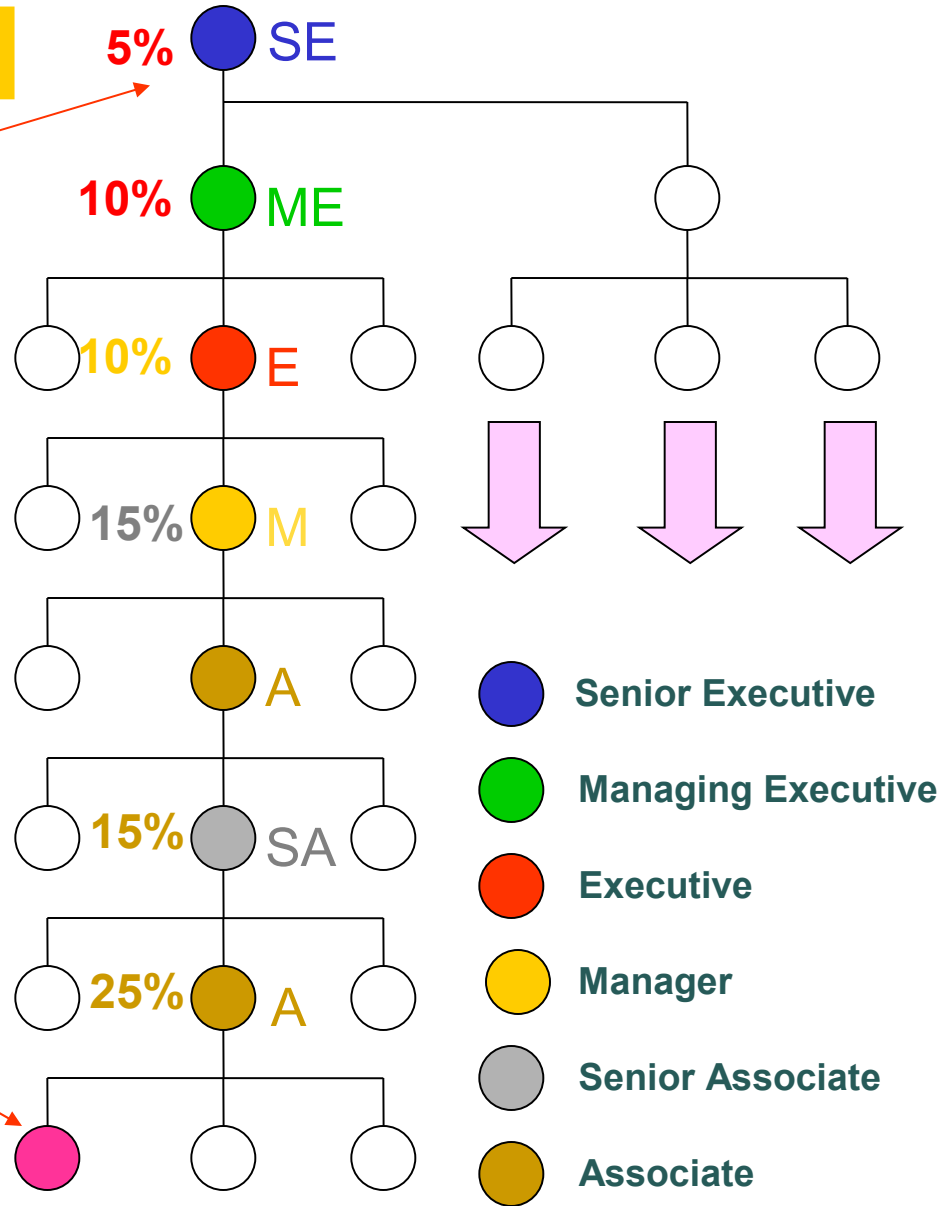

INDEX

RETIREMENT BONUSES

Retirement Bonuses are paid to Active Representatives according to rank, on the BV of all orders made by downline Representatives and Retailers who have been with ONE Group for more than 30 days.

Retirement Bonuses are paid on the 16th day of the following month and proceeds are paid immediately into the Representative's Bonus Account where they will have immediate access to the funds.

Retirement Bonuses are based on compressed generations according to rank.

Continue

RETIREMENT BONUSES

3% + 3% + 3% + 3%

3% + 3% + 3% + 3%

3% + 3% + 3% + 3%

3% + 3% + 3%

SE ME E M SA A

100 BV Order

An example of the Retirement Bonus payout (%) for this order

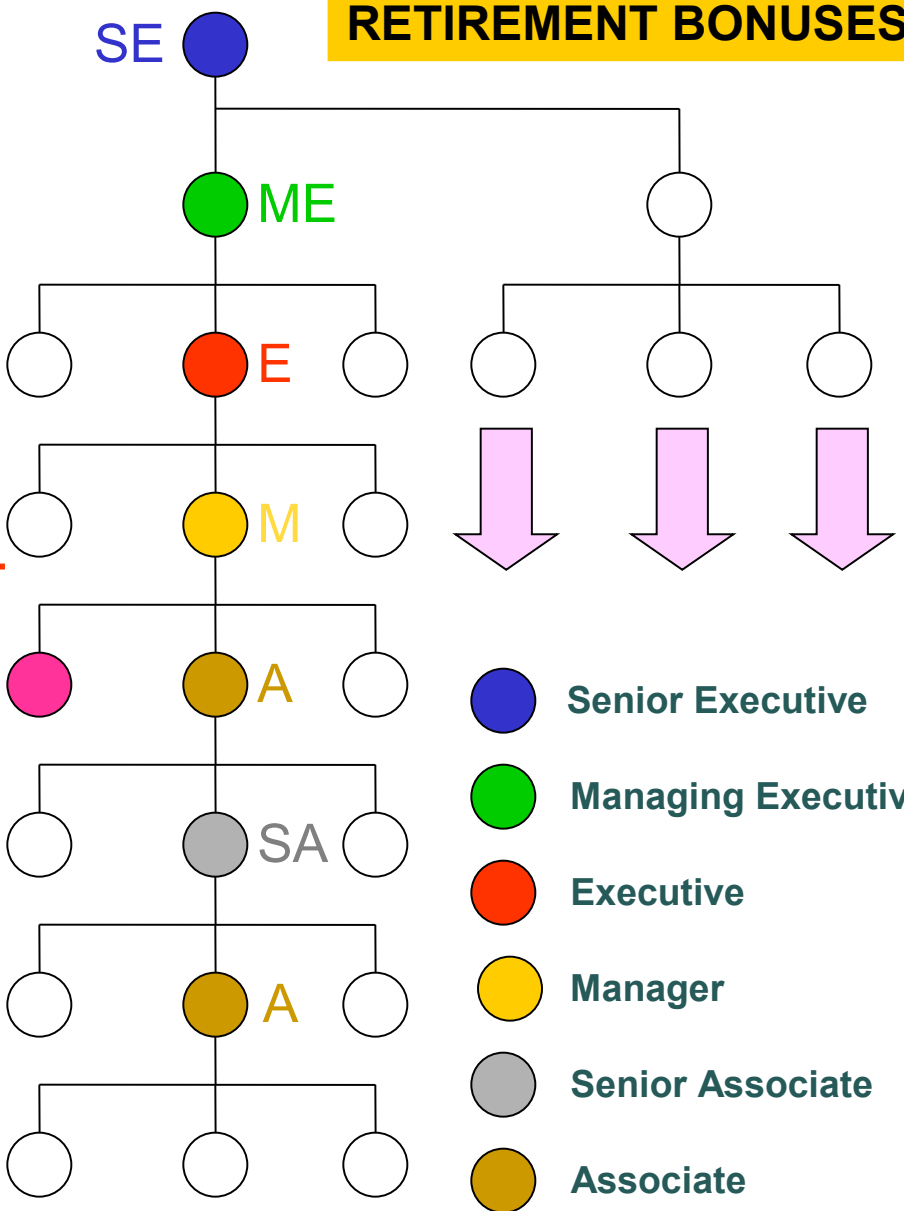

- Senior Executive
- Managing Executive
- Executive
- Manager
- Senior Associate
- Associate

Continue

RETIREMENT BONUSES

3%+ 3%+ 3%+ 3%

3%+ 3%+ 3%

3%+ 3%+ 3%

3%+ 3%

3%+ 3%

3%

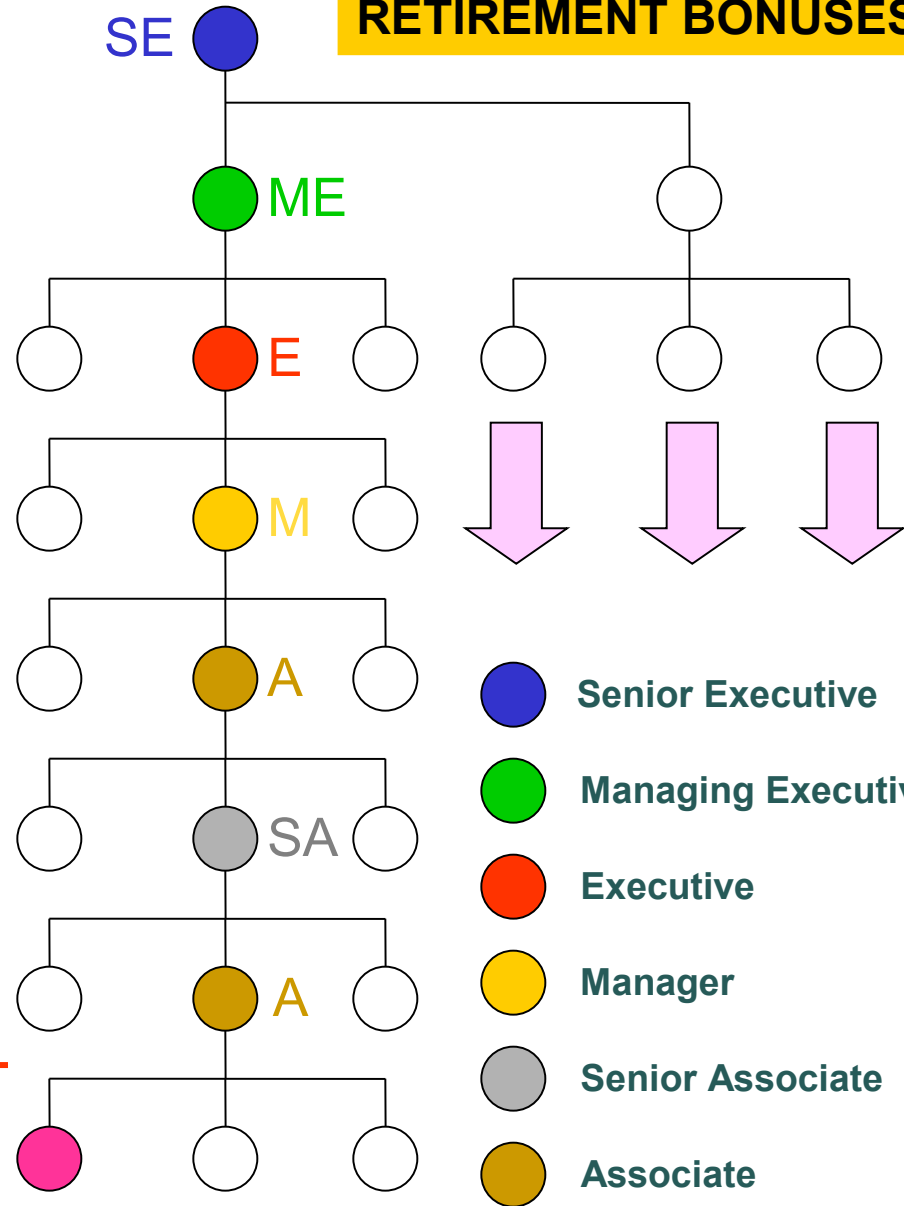

An example of the Retirement Bonus payout (%) for this order

SE ME E M SA A

100 BV Order

- Senior Executive
- Managing Executive
- Executive
- Manager
- Senior Associate
- Associate

INDEX

BUILDER'S BONUS

15% of the BV, generated through the Sponsor Tree, worldwide, is allocated to the Builder's Bonus. Active Representatives receive US \$50.00 for every Representative they sponsor who order a minimum of 250 PV in the **same calendar month**.

The Builder's Bonus is run daily and will clear after 15 days.

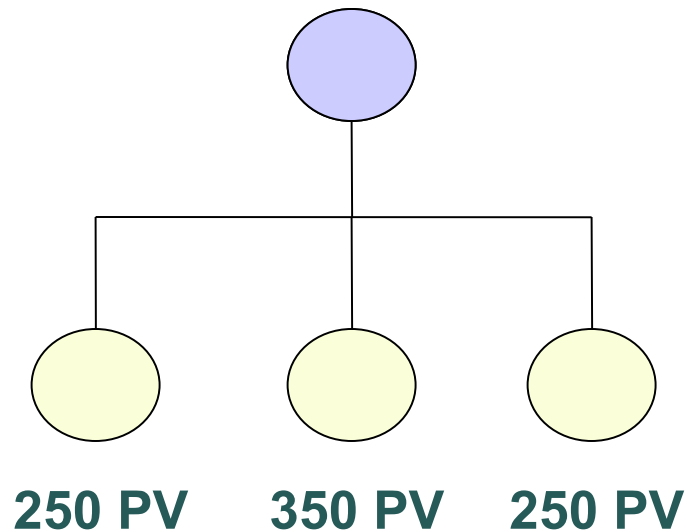

To qualify, the new Representative must join and place a 250 + PV order in the same calendar month

INDEX

LOYALTY BONUS

19% of worldwide Retirement BV is allocated to the Loyalty Bonus. Active Representatives, on Autoship or Business Protection, receive US \$70.00 each month they have 3 personally sponsored Representatives on at least 50 PV Autoship or BP and who have been with ONE Group for more than 30 days.

There are no limits to the number of shares a Representative may receive each month. The Loyalty Bonus is paid on the 16th day of the following month.

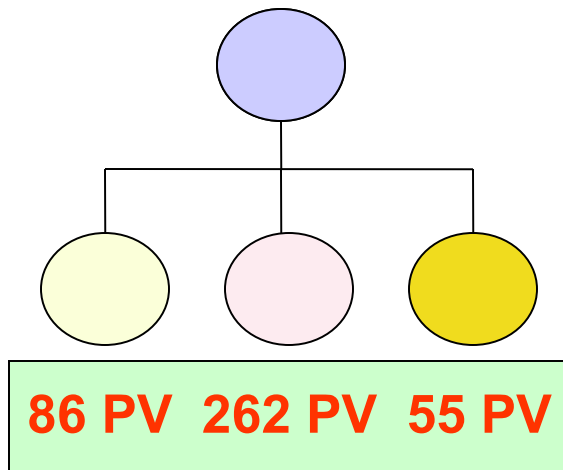

1 Share

Hypothetical Example

If a Representative has 9 personally sponsored Representatives on BP or AS they will receive US \$210.00 (3 shares)

INDEX

EXECUTIVE POOLS

In addition to the Retirement Bonuses, **Active** Executives, Managing Executives & Senior Executives will receive a share of the Executive Pool.

The Executive Pools are paid on the 16th day of the following month.

Qualified Executives, Managing Executives and Senior Executives will receive 1 share of 7% of worldwide Retirement BV.

Qualified Managing Executives and Senior Executives will receive 1 share of 5% of worldwide Retirement BV.

Qualified Senior Executives will receive 1 share of 3% of worldwide Retirement BV.

INDEX

BONUS PAYOUT

Sponsor Bonuses, as well as **Customer Bonuses** are run on a daily basis. However, because there is a 15-day money-back guarantee on product orders, the bonuses will only appear in the Member's **"UNCLEARED FUNDS"** account. Once the 15-day guarantee period has lapsed, funds will be moved into the Member's **CLEARED FUNDS** account where they will have immediate access to their money. **All other bonuses, including Pools**, are run on the 16th of the following month, so the funds will go straight into their **CLEARED FUNDS** Account.

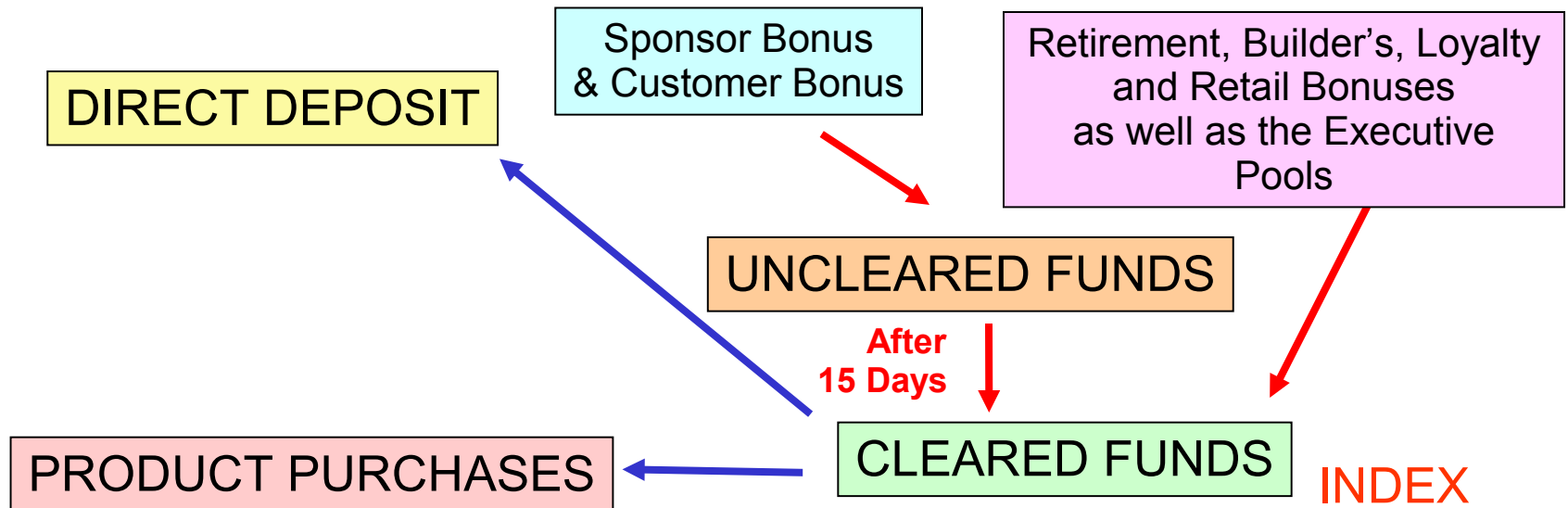

PROMOTION

Bonuses are paid to active Representatives according to their rank. Ranks are based on the number of active personally sponsored Representatives, their own Group Volume as well as the Group Volume of the Teams in their Retirement Tree.

Once promoted, a Representative will always keep their rank, however they will only be paid bonuses at the rank they are qualified for. In other words, if a Representative attained the rank of Executive in March, but only qualified at Manager in May, they will still be called an Executive, but will be paid as a Manager.

Continue

PROMOTION TO MANAGER

This is the normal way to attain the rank of Manager. For a faster way click 

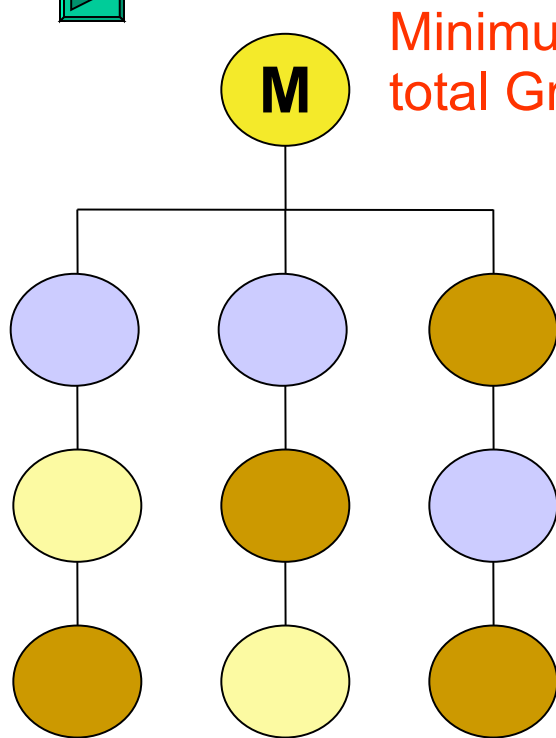

Minimum of 2,500
total Group Volume

A Manager needs at least 3 **Active**
Personally Sponsored Representatives.

-  Personally Sponsored Representative
-  Retailer placed by Upline Representative
-  Representative placed by Upline Representative

3 Teams with a minimum
of 500 Group Volume each

INDEX

ASSOCIATE

Maintenance & Promotion

Maintenance 50 PV / Month

Retirement Bonus Summary

3%

3%

Customer Bonuses

2 Generations of Associate or higher

Sponsor Bonuses

2 Compressed levels

25%, 15%

US\$50 Builder's Bonus

US\$70 Loyalty Bonus

Continue

SENIOR ASSOCIATE

Maintenance & Promotion

Maintenance	50 PV / Month	
# of active personally sponsored Representatives	2	
Minimum # of Teams	2	
Minimum Team GV	100	
Minimum Total GV	500	

Customer & Retail Bonuses

Sponsor Bonuses

3 Compressed levels
25%, 15%, 15%

US\$50 Builder's Bonus

Retirement Bonus Summary

3%	3%
3%	3%
	3%

2 Generations of Associate or higher +
3 Generations of Snr. Assoc. or higher

US\$70 Loyalty Bonus

Continue

MANAGER

Maintenance & Promotion

Maintenance	50 PV / Month	
# of active personally sponsored Representatives		3
Minimum # of Teams		3
Minimum Team GV	500	
Minimum Total GV	2,500	

Customer & Retail Bonuses

Sponsor Bonuses

4 Compressed levels
25%, 15%, 15%, 10%

US\$50 Builder's Bonus

Retirement Bonus Summary

3%	3%	3%
3%	3%	3%
	3%	3%
		3%

2 Generations of Associate or higher +
3 Generations of S. Assoc. or higher +
4 Generations of Manager or higher

US\$70 Loyalty Bonus

Continue

EXECUTIVE

Maintenance & Promotion

Maintenance	50 PV / Month
# of active personally sponsored Representatives	5
Minimum # of Teams	3
Minimum Team GV	2,000
Minimum Total GV	10,000

Customer & Retail Bonuses

Sponsor Bonuses

6 Compressed levels

25%, 15%, 15%,
10%, 10%, 5%

US\$50 Builder's Bonus

Retirement Bonus Summary

3%	3%	3%	3%
3%	3%	3%	3%
	3%	3%	3%
		3%	3%

- 2 Generations of Associate or higher +
- 3 Generations of S. Assoc. or higher +
- 4 Generations of Manager or higher +
- 4 Generations of Executive or higher

Executive Pool

US\$70 Loyalty Bonus

Continue

MANAGING EXECUTIVE

Maintenance & Promotion

Maintenance	50 PV / Month
# of active personally sponsored Representatives	7
Minimum # of Teams	3
Minimum Team GV	5,000
Minimum Total GV	25,000

Customer & Retail Bonuses

Sponsor Bonuses

7 Compressed levels

25%, 15%, 15%,
10%, 10%, 5%, 5%

US\$50 Builder's Bonus

Retirement Bonus Summary

3%	3%	3%	3%	3%
3%	3%	3%	3%	3%
	3%	3%	3%	3%
		3%	3%	3%

2 Generations of Associate or higher +
3 Generations of S. Assoc. or higher +
4 Generations of Manager or higher +
4 Generations of Executive or higher +
4 Generations of Man. Exec. or higher

2 Executive Pools

US\$70 Loyalty Bonus

Continue

SENIOR EXECUTIVE

INDEX

Maintenance & Promotion

Maintenance	50 PV / Month
# of active personally sponsored Representatives	10
Minimum # of Teams	3
Minimum Team GV	10,000
Minimum Total GV	50,000

Customer & Retail Bonuses

Sponsor Bonuses

7 Compressed levels

25%, 15%, 15%,
10%, 10%, 5%, 5%

US\$50 Builder's Bonus

Retirement Bonus Summary

3%	3%	3%	3%	3%	3%
3%	3%	3%	3%	3%	3%
	3%	3%	3%	3%	3%
		3%	3%	3%	3%
					3%

2 Generations of Associate or higher +
3 Generations of S. Assoc. or higher +
4 Generations of Manager or higher +
4 Generations of Executive or higher +
4 Generations of Man. Exec. or higher +
5 Generations of Senior Executive

3 Executive Pools

US\$70 Loyalty Bonus

ASSOCIATE	SNR. ASSOCIATE	MANAGER	EXECUTIVE	MAN. EXECUTIVE	SNR. EXECUTIVE
Maint. & Promotion	Maint. & Promotion	Maint. & Promotion	Maint. & Promotion	Maint. & Promotion	Maint. & Promotion
50 PV/Month	50 PV/Month 2 Active Personally Sponsored Reps Total GV: 500 2 Teams with a Min. 100 GV each	50 PV/Month 3 Active Personally Sponsored Reps Total GV: 2,500 3 Teams with a Min. 500 GV each	50 PV/Month 5 Active Personally Sponsored Reps Total GV: 10,000 3 Teams with a Min. 2,000 GV each	50 PV/Month 7 Active Personally Sponsored Reps Total GV: 25,000 3 Teams with a Min. 5,000 GV each	50 PV/Month 10 Active Personally Sponsored Reps Total GV: 50,000 3 Teams with a Min. 10,000 GV each
Customer Bonus	Customer Bonus	Customer Bonus	Customer Bonus	Customer Bonus	Customer Bonus
Up to 30% of Retail	Up to 30% of Retail	Up to 30% of Retail	Up to 30% of Retail	Up to 30% of Retail	Up to 30% of Retail
Retail Bonus	Retail Bonus*	Retail Bonus	Retail Bonus	Retail Bonus	Retail Bonus
Not Eligible	5% of Retail	5% of Retail	5% of Retail	5% of Retail	5% of Retail
Builder's Bonus	Builder's Bonus	Builder's Bonus	Builder's Bonus	Builder's Bonus	Builder's Bonus
US\$50	US\$50	US\$50	US\$50	US\$50	US\$50
Sponsor Bonuses	Sponsor Bonuses	Sponsor Bonuses	Sponsor Bonuses	Sponsor Bonuses	Sponsor Bonuses
25%, 15%	25%, 15%, 15%	25%, 15%, 15%, 10%	25%, 15%, 15%, 10% 10%	25%, 15%, 15%, 10% 10%, 5%	25%, 15%, 15%, 10% 10%, 5%, 5%
Retirement Bonuses	Retirement Bonuses	Retirement Bonuses	Retirement Bonuses	Retirement Bonuses	Retirement Bonuses
3% 3%	3%+3% 3%+3% 3%	3%+3%+3% 3%+3%+3% 3%+3%	3%+3%+3%+3% 3%+3%+3%+3% 3%+3%+3%	3%+3%+3%+3%+3% 3%+3%+3%+3%+3% 3%+3%+3%+3%	3%+3%+3%+3%+3%+3% 3%+3%+3%+3%+3%+3% 3%+3%+3%+3%+3% 3%+3%+3%+3% 3%
2 Generations of Associate or higher	2 Generations of Associate or higher + 3 Generations of Snr. Assoc. or higher	2 Generations of Associate or higher + 3 Generations of Snr. Assoc. or higher + 4 Generations of Manager or Higher	2 Generations of Associate or higher + 3 Generations of Snr. Assoc. or higher + 4 Generations of Manager or Higher + 4 Generations of Executive or higher	2 Generations of Associate or higher + 3 Generations of Snr. Assoc. or higher + 4 Generations of Manager or Higher + 4 Generations of Executive or higher + 4 Generations of Man. Exec. or higher	2 Generations of Associate or higher + 3 Generations of Snr. Assoc. or higher + 4 Generations of Manager or Higher + 4 Generations of Executive or higher + 4 Generations of Man. Exec. or higher + 5 Generations of Senior Executive
	* Only applicable to Senior Associate's w ho qualified prior to the policy change 1 June 06				
US\$70 Loyalty Bonus	US\$70 Loyalty Bonus	US\$70 Loyalty Bonus	1 Executive Pool US\$70 Loyalty Bonus	2 Executive Pools US\$70 Loyalty Bonus	3 Executive Pools US\$70 Loyalty Bonus

GETTING STARTED

The first thing to decide is whether to be a Preferred Customer or a Representative.

There is NO cost for becoming a Preferred Customer.

However, if you want to build a business to earn extra income, you will need to become a Representative by paying the Joining Fee. Just complete the Application together with an order and submit them to the Company.

If you choose to commit to either Autoship or Business Protection, a **completed Credit Card Authorisation Form must be forwarded to ONE Group.**

The quickest and most efficient way to join ONE Group is online at <http://yoursponsorsusername'.mionegroup.com>

Continue

GETTING STARTED

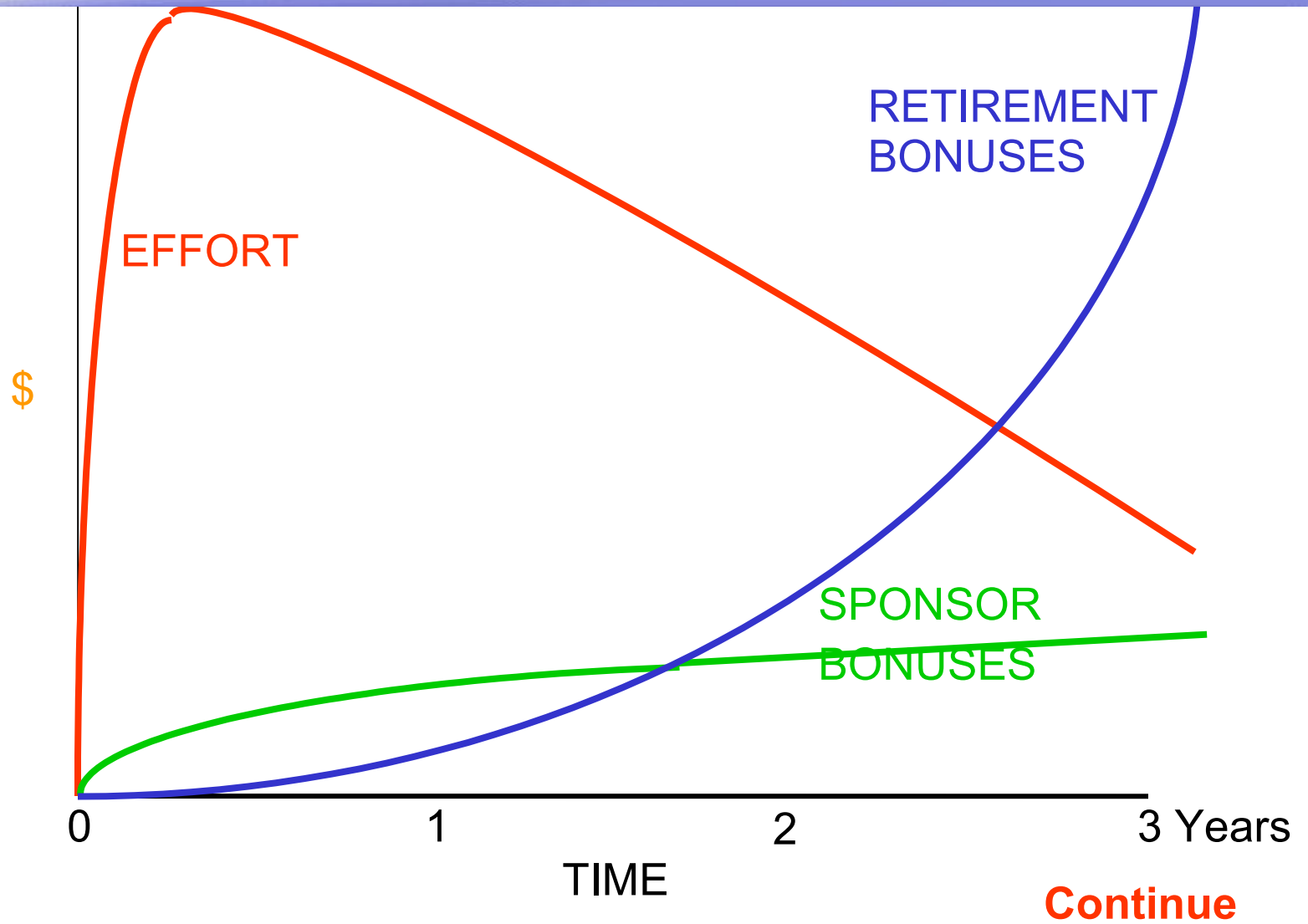

OFF TO A FAST START

A Representative whose orders total **250 PV +** within 30 days of joining, will be immediately promoted to Senior Associate.

Remember, single orders over 250 PV attract a 30% discount.

If, within their first 30 days, a Senior Associate personally sponsors, at least 3 Representatives who also attain the rank of Senior Associate, they will be promoted to Manager for the following 6 months. After the 6-month period has lapsed, if the “Grandfathered” Manager has not attained the rank of Manager in their own right, they will revert to Senior Associate.

250 PV in the first 30 days

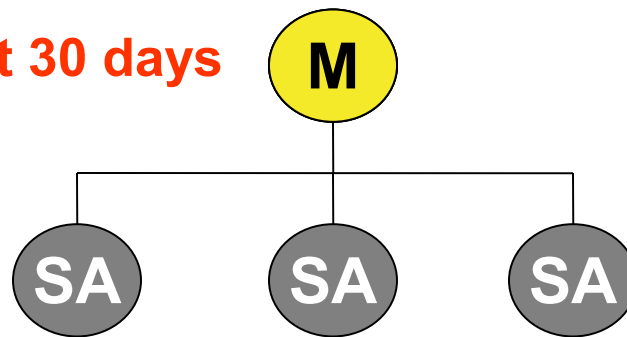

250 PV in the first 30 days

INDEX

Continue

SUMMARY

Thank you for taking the time to go through this presentation.

In summary, you must decide whether to become a Customer or a Representative.

If you decide to become a Representative, you have to decide how to start.

What products you will order?

Are you going to Fast Start with a 250 PV order?

You also have to decide whether you are going on Autoship or Business Protection.

Then just complete a couple of simple forms and you are on your way.

Continue

MAKE A DECISION

MAKE A COMMITMENT

& PERSEVERE